

- Commande frontale extérieure
 - Frontale externe bediening
 - External front control
 - externe Stirnsteuerung
 - Mando frontal exterior
 - Comando frontale esterno
- 221 42/.../48 - 221 52/.../58 - 222 74/75 - 227 33

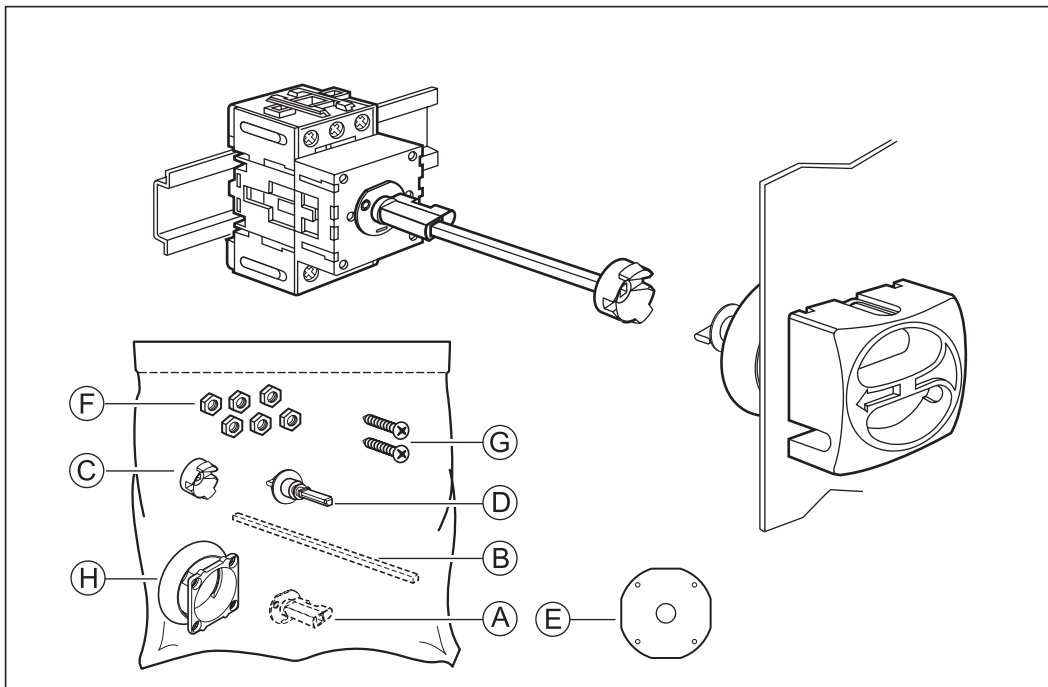

- Assemblage
- Assemblage

- Assembly
- Zusammenbau

- Ensamblaje
- Assemblaggio

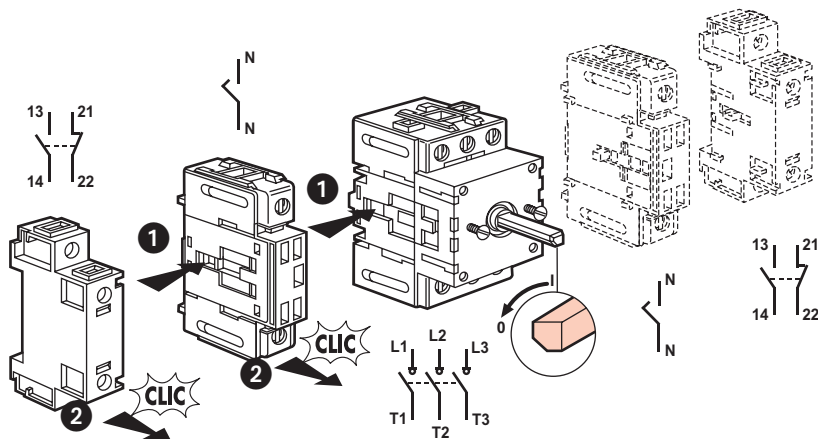

- Assemblage
- Assemblage

- Assembly
- Zusammenbau

- Ensamblaje
- Assemblaggio

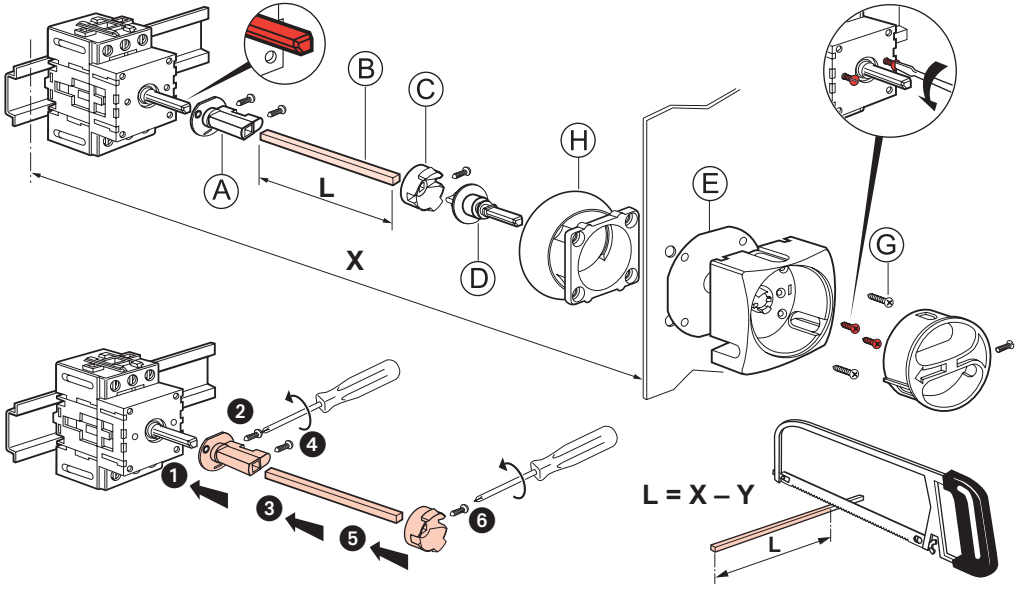

	Y (mm)	X (mm)	X (mm)
20 - 32A	92	$125 \leq X \leq 250$	$125 \leq X \leq 400$
50 - 63A	102	$135 \leq X \leq 260$	$135 \leq X \leq 410$
80 - 100A	112	$145 \leq X \leq 270$	$145 \leq X \leq 420$

	Y (")	X (")	X (")
20 - 32A	3,62	$4,92 \leq X \leq 9,84$	$4,92 \leq X \leq 15,7$
50 - 63A	4,02	$5,31 \leq X \leq 10,24$	$5,31 \leq X \leq 16,14$
80 - 100A	4,51	$5,71 \leq X \leq 10,63$	$5,71 \leq X \leq 16,53$

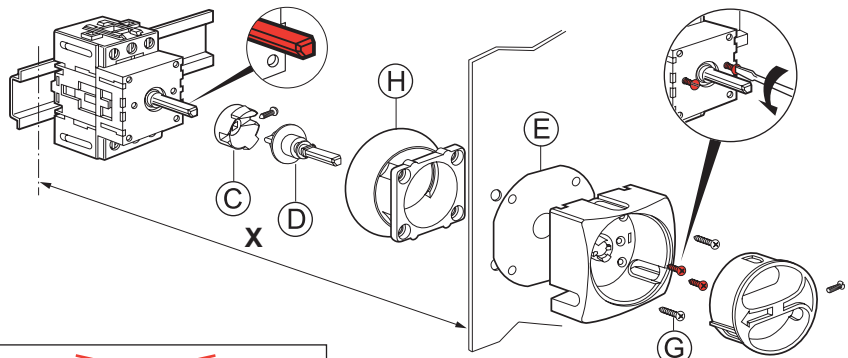

	X (mm)	X (")
20 - 32A	$85 \leq X \leq 100$	$3,35 \leq X \leq 3,94$
50 - 63A	$96 \leq X \leq 110$	$3,78 \leq X \leq 4,33$
80 - 100A	$106 \leq X \leq 120$	$4,17 \leq X \leq 4,72$

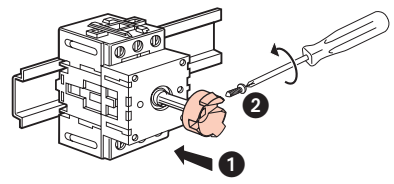

- Assemblage
- Assemblage

- Assembly
- Zusammenbau

- Ensamblaje
- Assemblaggio

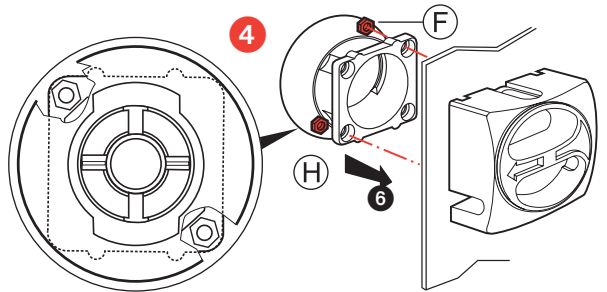
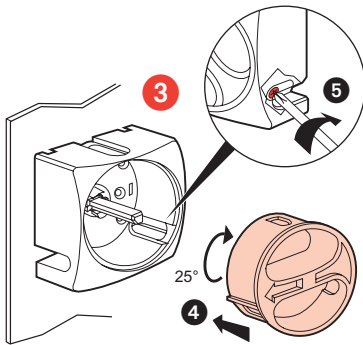
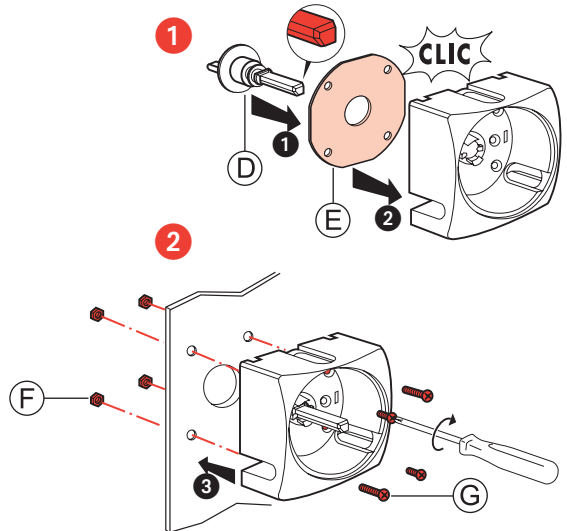
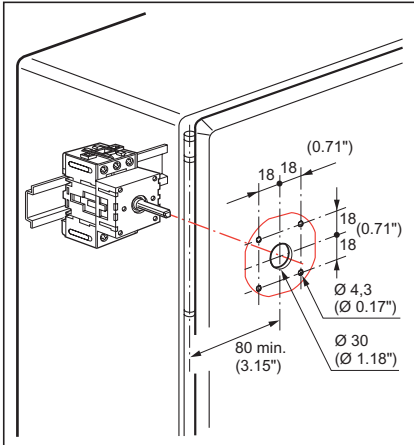

- Montage
- Montage

- Mounting
- Montage

- Montaje
- Montaggio

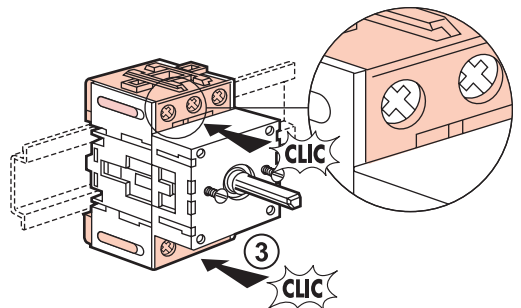
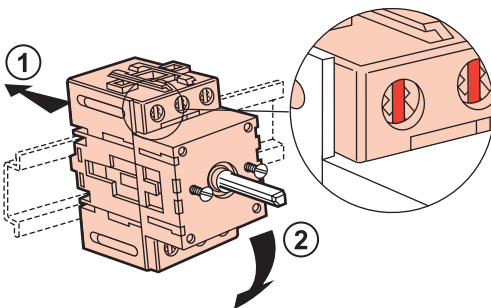

- Tout déplacement du bornier (montage encastré/saillie) doit se faire après avoir dévissé complètement toutes les vis.
- Elke verplaatsing van het aansluitblok (in-/opbouwmontage) mag enkel gebeuren na het volledig uitschroeven van alle schroeven.
- Every move of the terminal block (flush-mounting/surface-mounting) is to be carried out with all screws completely loosened.
- Jede Bewegung des Klemmenblocks (Unterputz-/Aufputz-Montage) muß nur ausgeführt werden, wenn alle Schrauben ganz gelöst worden sind.
- Cualquier desplazamiento de las bornas (montaje empotrado o saliente) debe hacerse después de desatornillar completamente todos los tornillos.
- Ogni spostamento del morsetto (montaggio ad incasso o sporgente) deve essere eseguito dopo avere svitato completamente le viti.

- Démontage
- Demontage

- Dismounting
- Ausbau

- Desmontaje
- Smontaggio

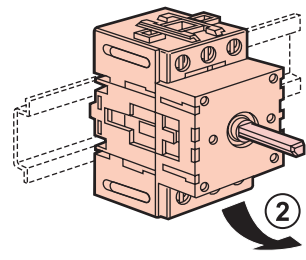
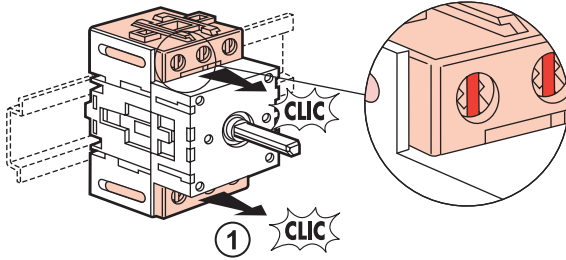

- Spécification UL-CSA
- UL-CSA specification

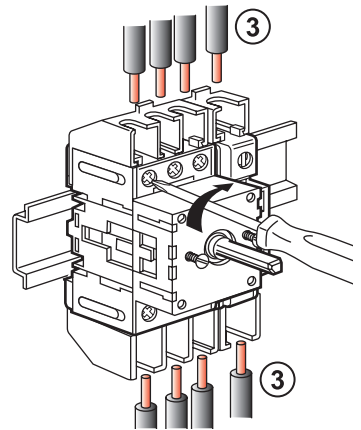
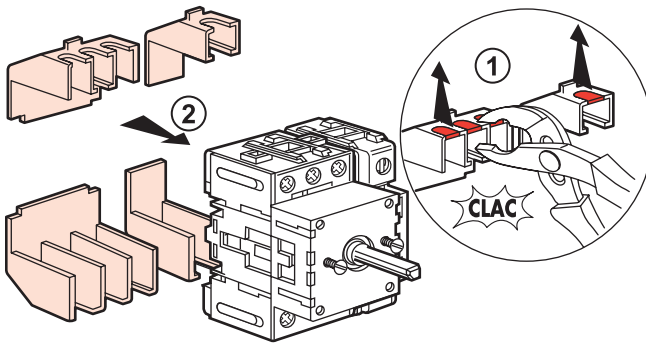

See table below for appropriate values

Type	Model N°	A. 1 Symmetrical Amps	Fuse rating	B. 2 Symmetrical Amps	Fuse rating	Torque value	Wire Size	Main Contacts
20 A	221 00	5000	40	5000	10	1.7 ft. lbs. (2,3 Nm)	8 - 14 AWG	
25 A	221 10	5000	40	5000	15			
32 A	221 30	5000	40	5000	20			
50 A	221 40	5000	80	5000	25	3.0 ft. lbs. (4,0 Nm)	4 - 14 AWG	
63 A	221 50	5000	80	5000	35			
80 A	221 70	5000	125	5000	60	4.1 ft. lbs. (5,6 Nm)	1 - 14 AWG	
100 A	221 80	10000	125	5000	70			
Auxiliary contact blocks	227 00 222 25 222 26 222 27					1.7 ft. lbs. (2,3 Nm)	14 - 18 AWG	

Short circuit rating (UL 508) :

A. Suitable for use on a circuit capable of delivering not more than ① rms symmetrical amperes, 600 V a.c. max, when protected by class K5 fuses.

B. Suitable for use Motor Disconnect on a circuit capable of delivering nor more than ② rms symmetrical amperes, 600 V a.c. max, when protected by class RK5 fuses.

• **Caution** : UL 508 Spacing Requirement CSA 22.2 n°14-M91 - For Rear or Din-Rail mounting of the 20A, 25A, 32A, 50A, or 63A switches in a metal enclosure it is required that the terminals maintain a minimum spacing of 1/2 in. (12,7 mm) from all metal parts. If this spacing is not satisfied proper terminal covers must be installed as shown below to meet UL 508 criteria. See listing at bottom of page for terminal cover parte numbers.

• **Précautions d'utilisation** : selon la norme CSA 22.2 n°14-M91 - Pour les interrupteurs sectionneurs 20A, 25A, 32A, 50A, ou 63A en montage saillie ou sur rail Din dans un boîtier métallique, il est recommandé de maintenir une distance minimale de 12,7 mm entre les bornes et toute partie métallique. Si cet espace n'est pas respecté, des cache-bornes spécifiques doivent être installés afin de répondre aux exigences de la norme.