

PHILIPS

Emergency downlight

EM120B

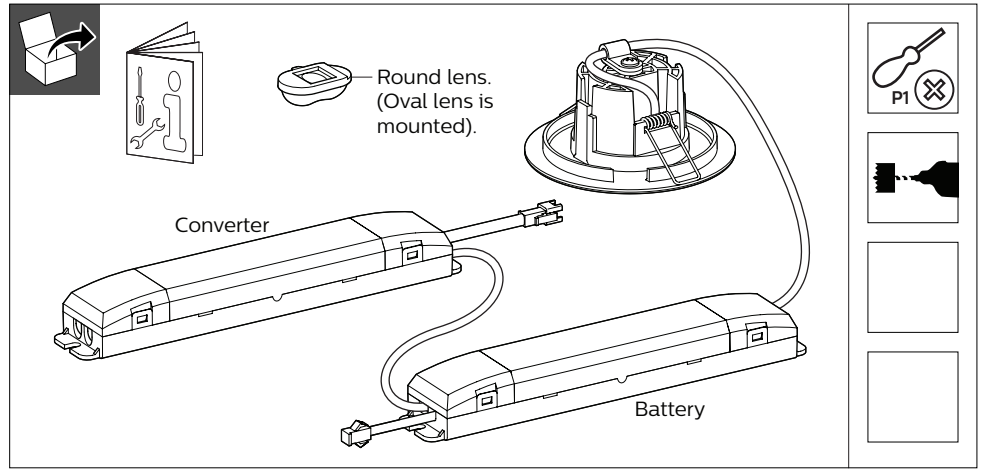

220V
240V

50Hz
60Hz



LEDs

IP20

GLOW WIRE
650 °C

Max. 40 °C
Min. 0 °C



Test	CCT (K)	Lumen (lm)	P (W)	Ø mm	kg
EM120B MT manual	600	185	4	68 - 72	
EM120B AT auto					

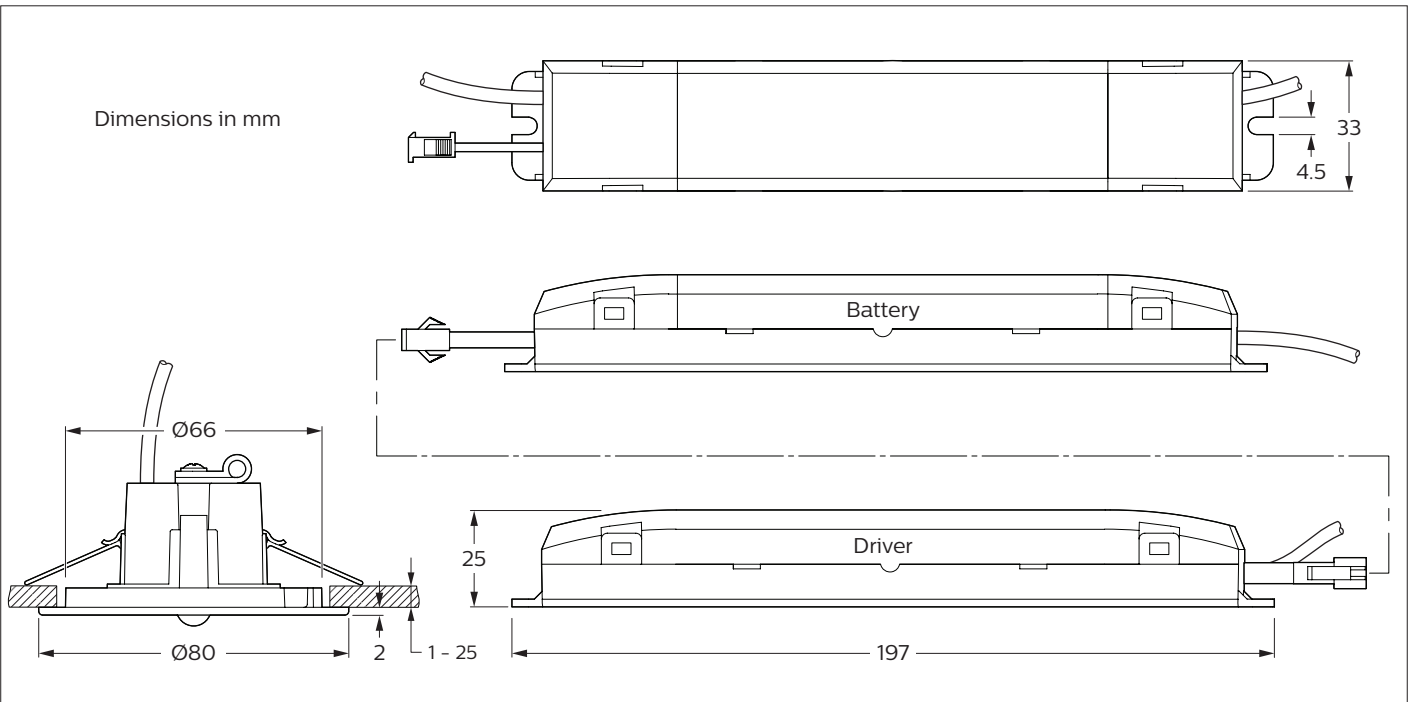

Inrush current

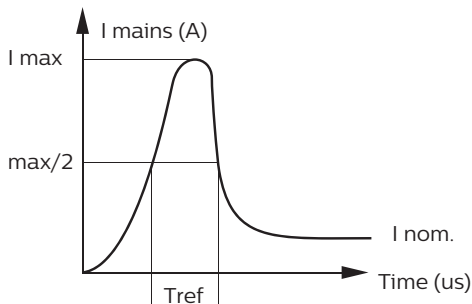

Electrical characteristics	
Inom (mA)	113
I _{max} (A)	48
T _{ref} (µs)	1.2
MCB	Downlights Max.
B-10 A	
B-13 A	
B-16 A	
C-10 A	
C-13 A	
C-16 A	



ATTENTION
OBSERVE PRECAUTIONS
FOR HANDLING
ELECTROSTATIC
SENSITIVE
DEVICES

- The luminaire shall be installed by a qualified electrician and wired in accordance with the latest IEE electrical regulations or the national requirements.
- The light source of this luminaire is not replaceable; when the light source reaches its end of life the whole luminaire shall be replaced.
- Clean with dry cloth.
- Philips Lighting warranty is applicable only if the indicated drivers are used.

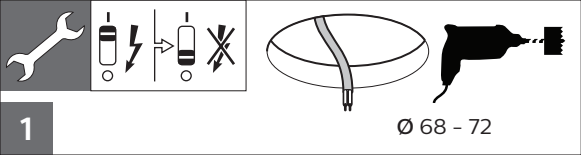
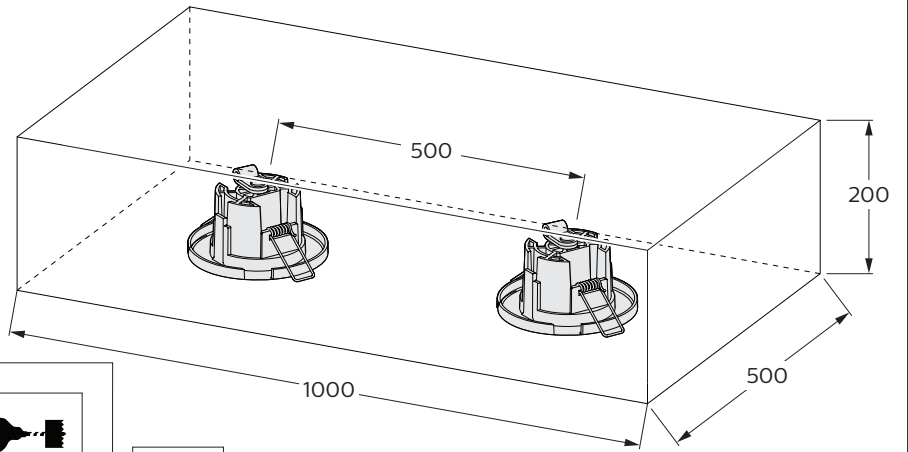
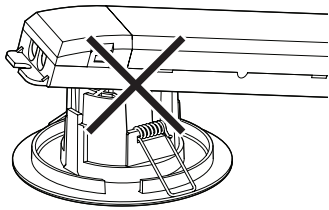

The luminaire shall, under no circumstance, be covered with thermal insulation matting or similar material.

1

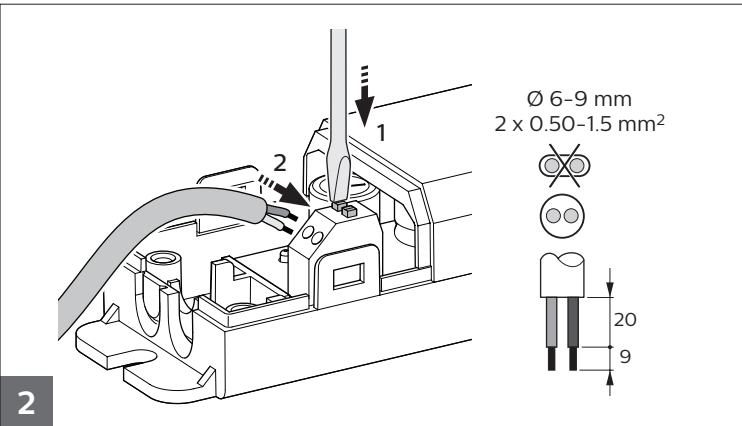

2

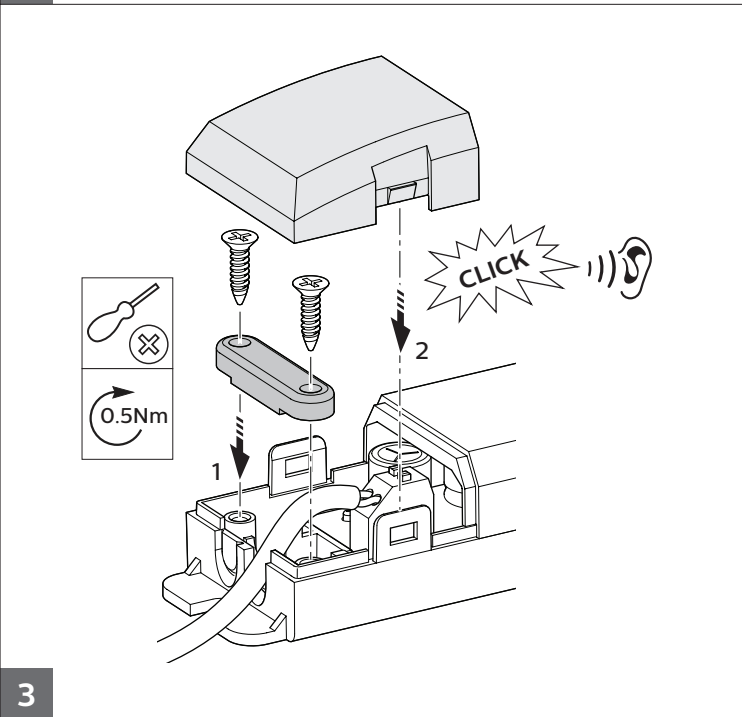

3

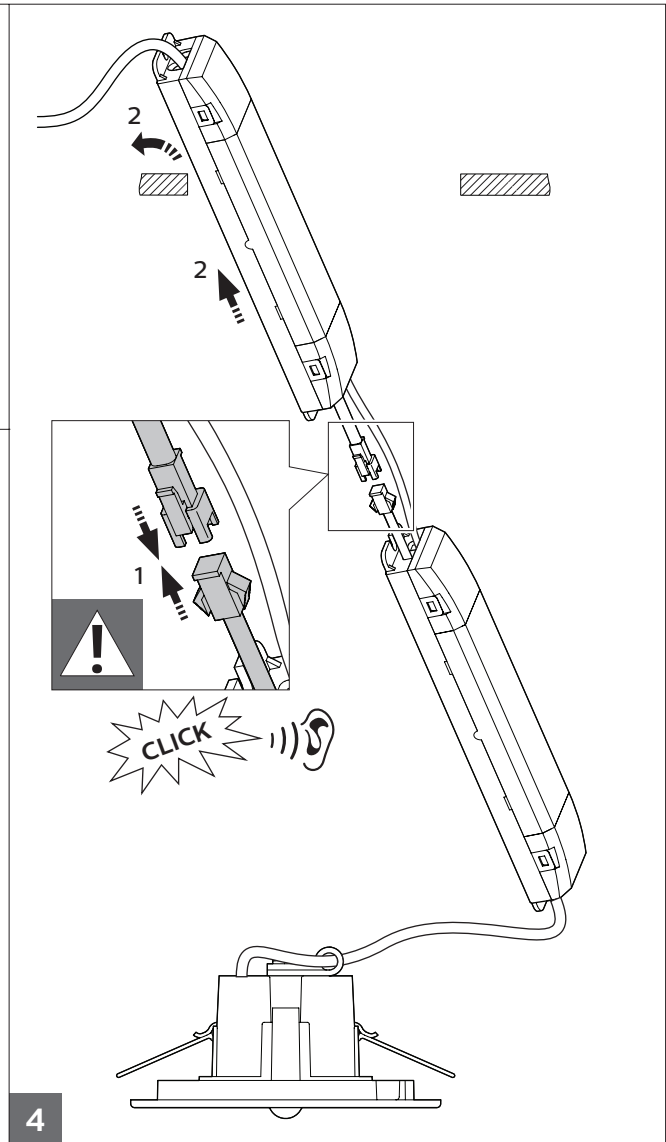

4

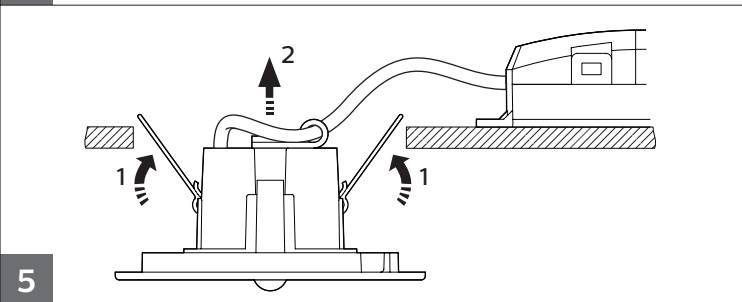

5

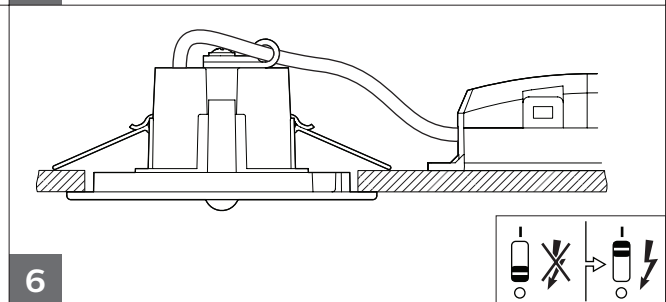

6



Replacement battery (lifetime 4 years)

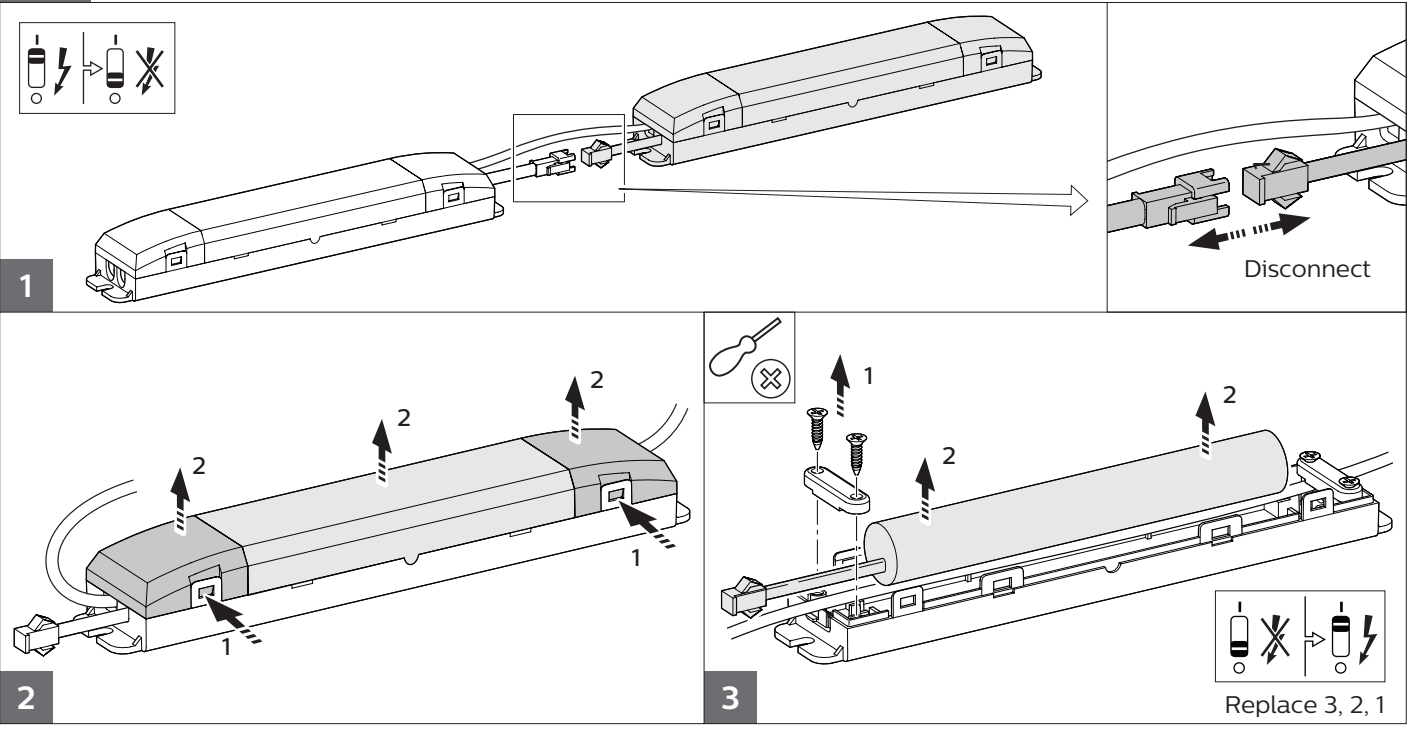

Replacement lens

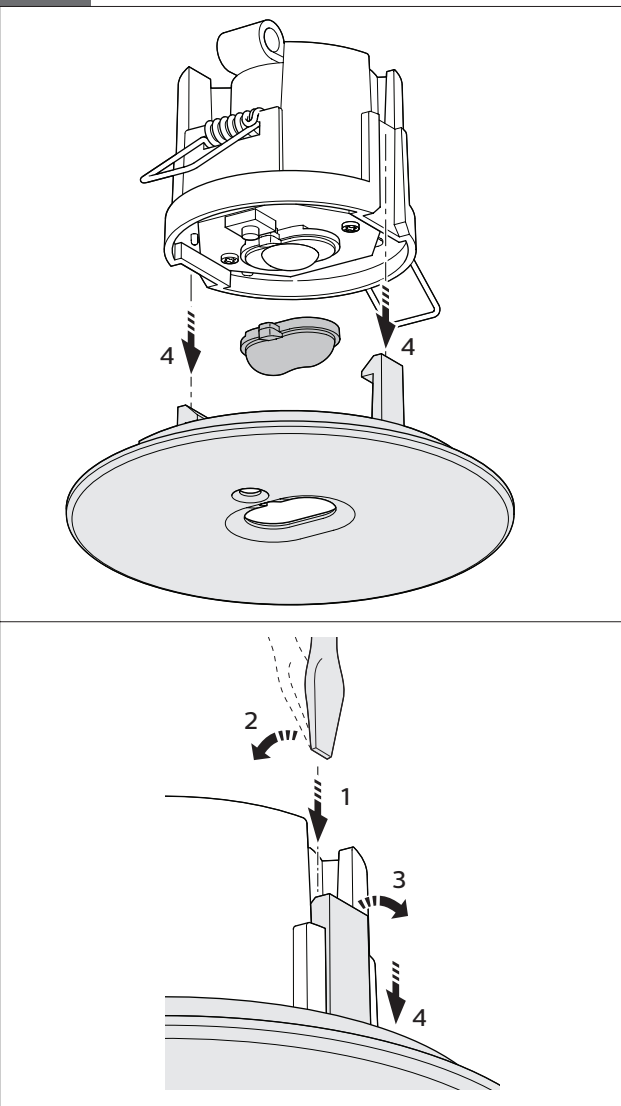

Oval lens for pathway application.

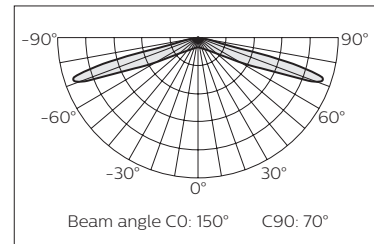

Mounting height (m)	Spacing distance (m)
2.5	16
3.0	18
3.5	20

Compliant EUROPE standard EN1838 illuminance requirement: Escape route up to 2 m wide, 1 lx on the central axis and 0.5 lx at 50% of the width.

Round lens for open area application.

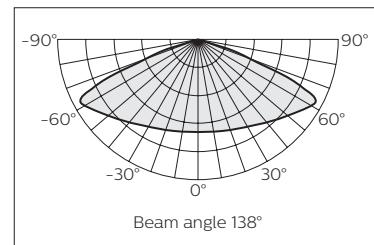

Mounting height (m)	Spacing distance (m)
2.5	8
3.0	9
3.5	10

Compliant EUROPE standard EN1838 illuminance requirement: Escape route up to 2 m wide, 1 lx on the central axis and 0.5 lx at 50% of the width.



Manual test version

Press test button once	30 second duration test
Press test button 2 times within 2 seconds	3 minute duration test
Press test button 3 times within 2 seconds	30 minute duration test
Press test button 4 times within 2 seconds	3 hours duration test

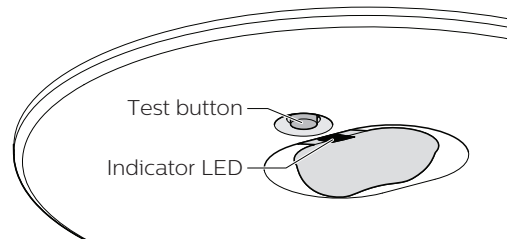

Self test version

Once the unit is powered up it will automatically initiate a self test and diagnostics as follows:

- Every 4 seconds : Checks for battery disconnection, charger board fault, lamp failure and transformer failure
- Every month : Performs a 3 minute duration test
- Every year : Performs a 1 Hour or 3 Hour duration test

Dual color indicator LED:

- Green solid on; Ready / normal operation
- Green flashing; Testing
- Red flashing; Requires service

*	One flash, 4 seconds pause	Battery not connected
**	Two flashes, 4 seconds pause	Battery short or low battery voltage
***	Three flashes, 4 seconds pause	Charger board fault
****	Four flashes, 4 seconds pause	Transformer board fault
*****	Five flashes, 4 seconds pause	LED lamp fault

Note 1: After repairing a service fault, press and hold the test button for 2 seconds to reset

Note 2: Manual testing also works with the self test unit

Charge time

