

Montageanleitung WKE 200-400 SL

Montage an Wand und Decke

Die Befestigung an Wand und Decke der WKE 200-400 SL erfolgt wie im „Allgemeinen bauaufsichtlichen Prüfzeugnis“ (AbP-Nr. P-1040 DMT DO) beschrieben.

Die dem Produkt beiliegenden Schraubanker besitzen eine Brandschutzzulassung für gerissenen und ungerissenen Beton der Festigkeitsklassen C20/25 bis C50/60 (siehe Abb. **01** und **02**). Entwässerungsöffnungen sind gemäß DIN EN 60670 bei Bedarf einzubringen.

Anschluss der Leitungen

Die Leitungen werden gemäß der Vorgaben in Tabelle **A** angeschlossen. Die Befestigung der Leitungen außerhalb der Dose erfolgt nach den Vorgaben des AbP. Abstand der ersten Befestigungsstelle 125mm ± 25mm von der Gehäuseaußenwand.

Installation Instruction WKE 200-400 SL

Installation on wall and ceiling







The WKE 200-400 SL is installed on the wall and on the ceiling as described in the "General building inspection test certificate" (AbP-Nr. P-1040 DMT DO).



The screw anchors that come with a fire protection approval are approved for cracked and uncracked concrete of strength categories C20/25 to C50/60 (See Figures **01** and **02**). Drainage openings must be integrated as needed as per DIN EN 60670.

Connection of lines

Connect the lines as specified in the table **A**. Outside the box, the lines are fastened as specified in the AbP. The distance of the first fixation point from the external wall of the casing is 125mm ± 25mm.

A Anschluss der Leitungen (abhängig von der Gehäusegröße) Connection of lines (depending on the enclosure size)

 Bemessungsquerschnitt Rated cross section	 Kabelquerschnitt (eindrätig) Cable cross section (single wire)	 Push-in Klemme (direkt steckbar) Push-in Cage Clamp (directly pluggable)	 Abisolierlänge Strip length	 Bemessungsisolationsspannung Rated insulation voltage	 Bemessungsstrom Rated current	 Verlustleistung Power loss
mm ²	mm ²	mm ²	mm			
6	0,5 - 6	2,5 - 6	13 - 15	600 V	41 A	-----
10	0,5 - 10	4 - 10	17 - 19	600 V	57 A	-----
16	0,5 - 16	6 - 16	18 - 20	600 V	76 A	-----
6mm ² (Sicherungsklemme / fuse terminal block)	0,2 - 6	-----	12-13	500 V	10 A	2,5 W

 Kabelverschraubung Cable gland	 Dichtbereich Sealing area
M20	6 - 13
M25	6 - 15
M32	9 - 19
M40	17 - 27
M50	23 - 34

01

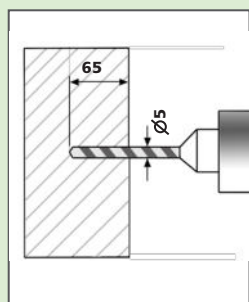

02

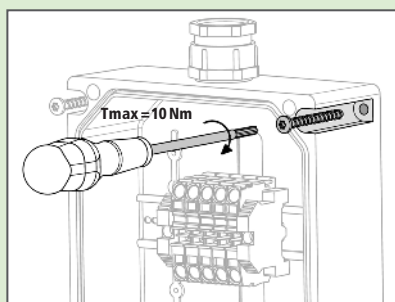

03

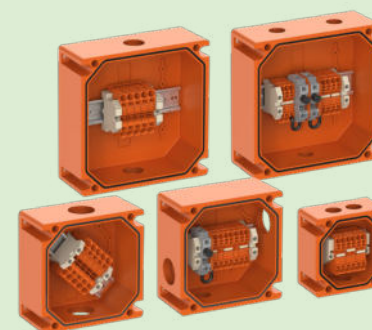
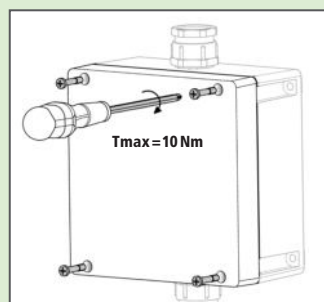

Günther Spelsberg GmbH + Co. KG

Im Gewerbepark 1, D-58579 Schalksmühle

Phone: +49 2355 892-0

Fax: +49 2355 892-299

E-Mail: info@spelsberg.de

Internet: www.spelsberg.de

Instructions de montage WKE 200-400 SL

Montage au mur et au plafond

Pour la fixation au mur et au plafond de la boîte de jonction WKE 200-400 SL procédez comme décrit dans le «Certificat d'essai général dans le cadre de la surveillance des constructions» (AbP-Nr. P-1040 DMT DO).

Les chevilles à vis fournies avec le produit sont homologuées pour la protection contre l'incendie, pour béton fissuré et non fissuré des classes de résistance C20/25 à C50/60 (voir fig. **01** et **02**). Des orifices de drainage doivent être mis en place selon les besoins, conformément à la norme DIN EN 60670.

Raccordement électrique

Raccordez les fils électriques conformément aux prescriptions du tableau **A**. Fixez les câbles électriques à l'extérieur de la boîte conformément aux prescriptions du certificat d'essai général dans le cadre de la surveillance des constructions. Distance du premier point de fixation 125mm ± 25mm de la paroi extérieure du boîtier.

Instrucciones de montaje WKE 200-400 SL

Montaje en paredes y techos







La fijación a techo o pared de la WKE 200-400 SL se lleva a cabo tal y como se describe en el "Certificado general de inspección de obras" alemán (AbP-Nr. P-1040 DMT DO).



Los anclajes de tornillo con certificado de resistencia al fuego que se entregan con el producto están homologados para ser utilizados en hormigón fisurado y no fisurado de las clases de resistencia C20/25 a C50/60 (véanse imágenes **01** y **02**). Si fuera necesario, las aberturas de drenaje deberán colocarse de conformidad con DIN EN 60670.

Conexión de los cables

Los cables se conectan según lo indicado en la tabla **A**. La fijación de los cables fuera de la caja se lleva a cabo según lo indicado en "Certificado general de inspección de obras" alemán. Distancia del primer punto de fijación 125 mm ± 25 mm de la pared exterior de la carcasa.

A Fixation / raccordement électrique Unión de los bornes / Conexión de los cables

 Section assignée Sección nominal	 Section de câble (monofilaire) Sección del cable (de un cable)	 Borne Push-in (directement enfichable) Abrazadera de presión (directamente enchufable)	 Longueur de dénudage Longitud a desaislar	 Tension nominale d'isolement Tensión nominal de aislamiento	 Courant assigné Intensidad nominal	 Puissance dissipée Potencia perdida
mm ²	mm ²	mm ²	mm			
6	0,5 - 6	2,5 - 6	13 - 15	600 V	41 A	-----
10	0,5 - 10	4 - 10	17 - 19	600 V	57 A	-----
16	0,5 - 16	6 - 16	18 - 20	600 V	76 A	-----
6mm ² (Borne porte-fusible / Abrazadera de seguridad)	0,2 - 6	-----	12-13	500 V	10 A	2,5 W

 Presse-étoupes Prensaestopa	 Zone étanche Área de estanqueidad
M20	6 - 13
M25	6 - 15
M32	9 - 19
M40	17 - 27
M50	23 - 34

01

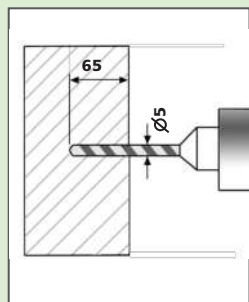

02

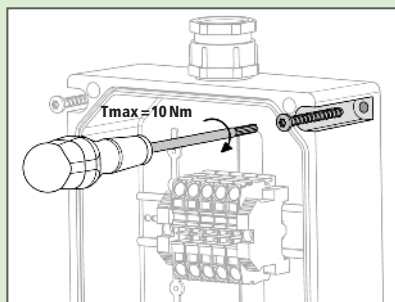

03

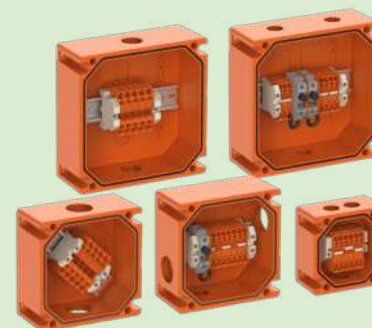
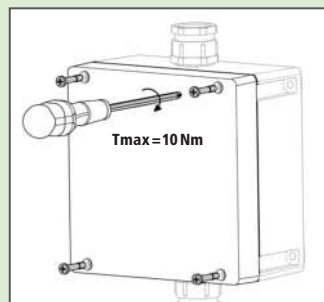

Günther Spelsberg GmbH + Co. KG

Im Gewerbepark 1, D-58579 Schalksmühle

Phone: +49 2355 892-0

Fax: +49 2355 892-299

E-Mail: info@spelsberg.de

Internet: www.spelsberg.de